

2) After installing the part and shimming, tuck a piece of backer rod/foam cord in the front face of the cut. The backer rod is designed to hold epoxy in the cut during cure.

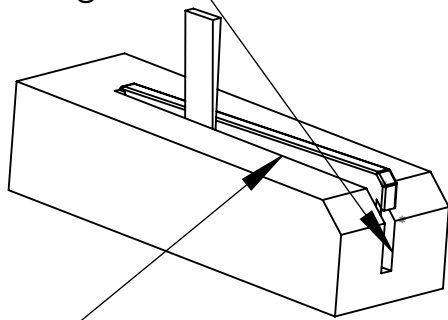

3) Tape part to protect finish prior to using epoxy. Inject self leveling epoxy into open joint. Fill to approx 1/2" below surface.

4) After epoxy has cured, remove shim and backer rod. Inject color matched caulk until flush to surface. For best results, apply matching sand on wet caulk joint.

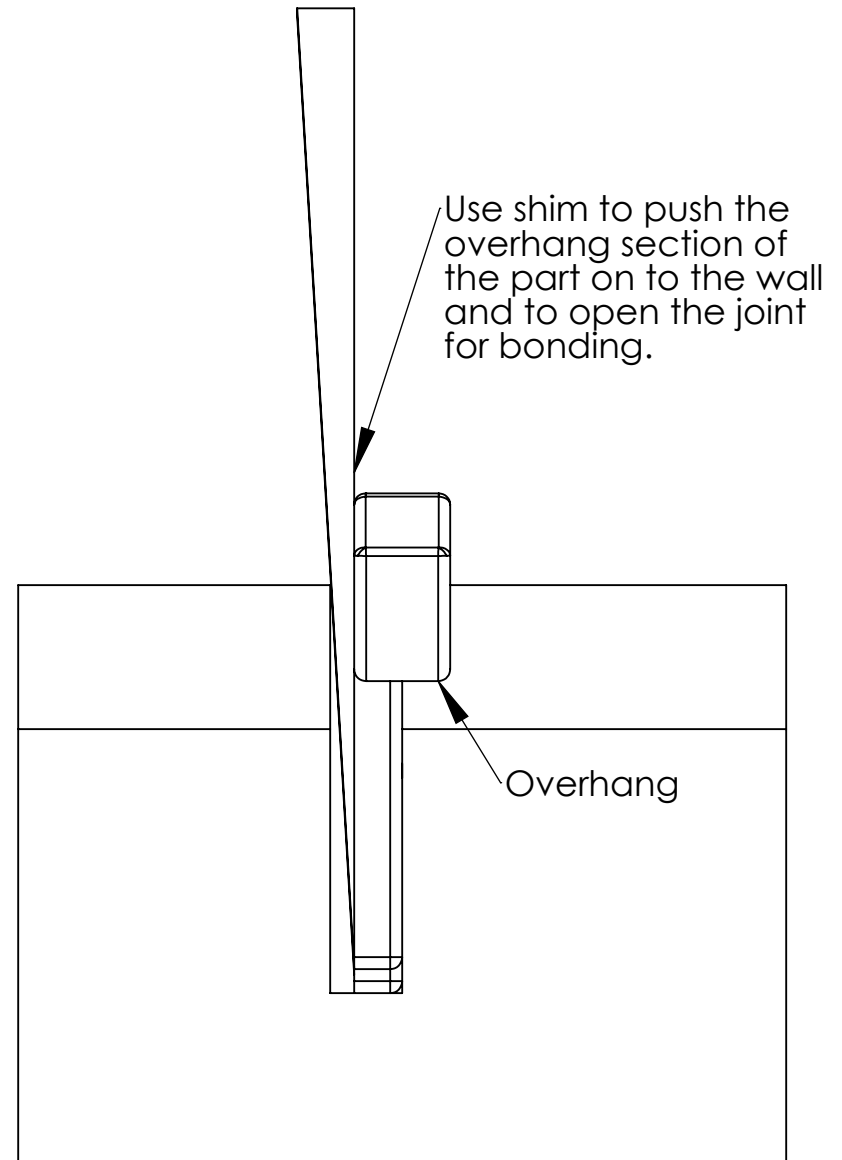

TITLE:

Bonding Setup

SIZE	DWG. NO.	REV
A	CutInDetailB	

SCALE: 1:5	WEIGHT: 1.74 lbs	SHEET 1 OF 1
------------	------------------	--------------

PROPRIETARY AND CONFIDENTIAL
THE INFORMATION CONTAINED IN THIS
DRAWING IS THE SOLE PROPERTY OF
INTELLICEPT. ANY REPRODUCTION IN
PART OR AS A WHOLE WITHOUT THE
WRITTEN PERMISSION OF
INTELLICEPT IS PROHIBITED.

MATERIAL

FINISH