

8 7 6 5 4 3 2 1

THE INFORMATION CONTAINED IN THIS DRAWING IS THE SOLE PROPERTY OF INTELLECT. ANY REPRODUCTION IN PART OR WHOLE WITHOUT THE WRITTEN PERMISSION OF INTELLECT IS PROHIBITED.

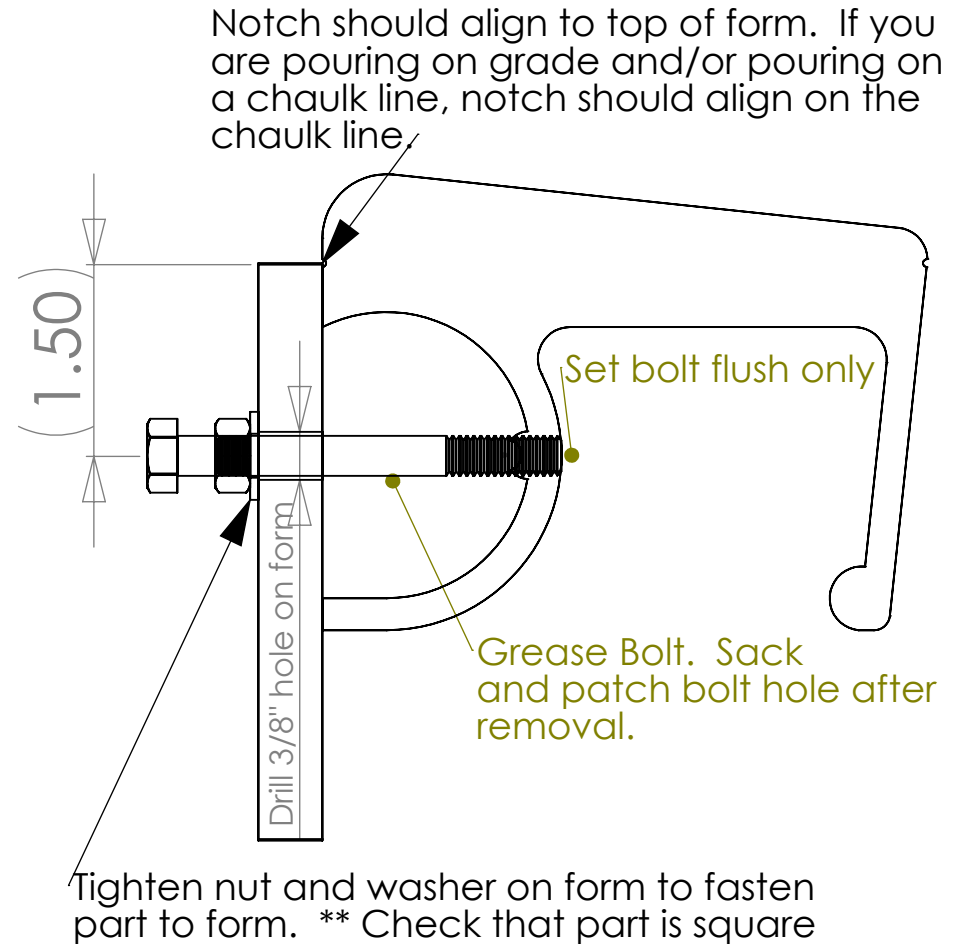
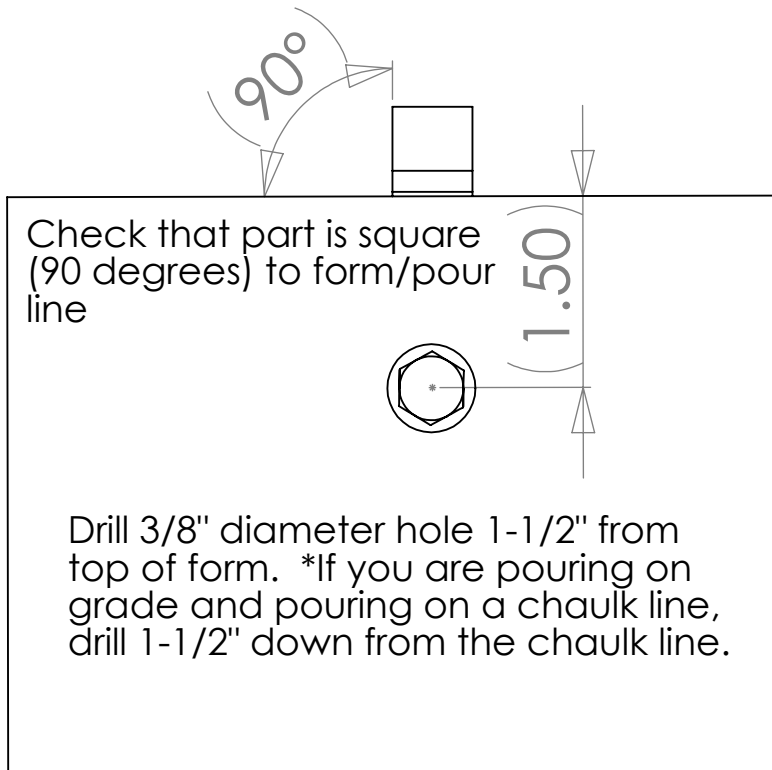

NOTE: F2 is best suited for 1/2" radius trowel edge (or less). F2 may be used for 1/2" chamfer. Do NOT use F2 on 3/4" chamfer or radius trowel greater than 1/2".

INTELLECT  
SAN DIEGO, CALIFORNIA, U.S.A.

## F2 Radius

SIZE A	DWG. NO.	REV.
SCALE	CAD FILE:	SHEET OF