

NOTE: INSERT part has a flat side and an overhang side. Drill holes only on the overhang side of the wall.

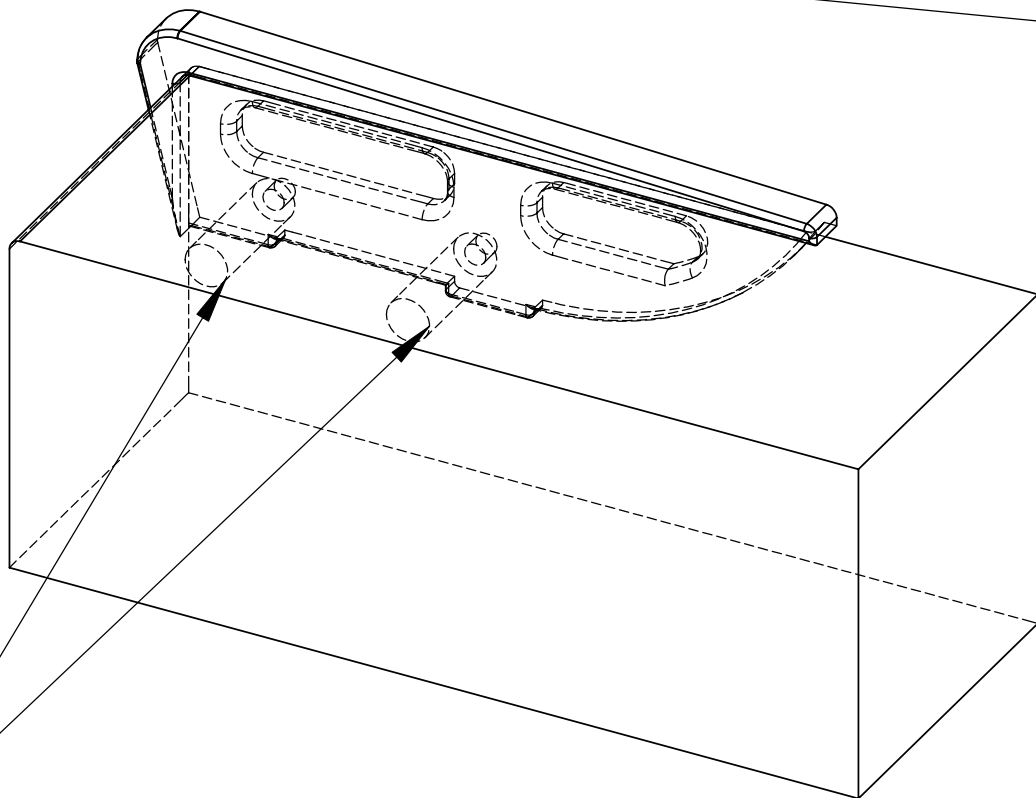

FLAT SIDE OVERHANG SIDE

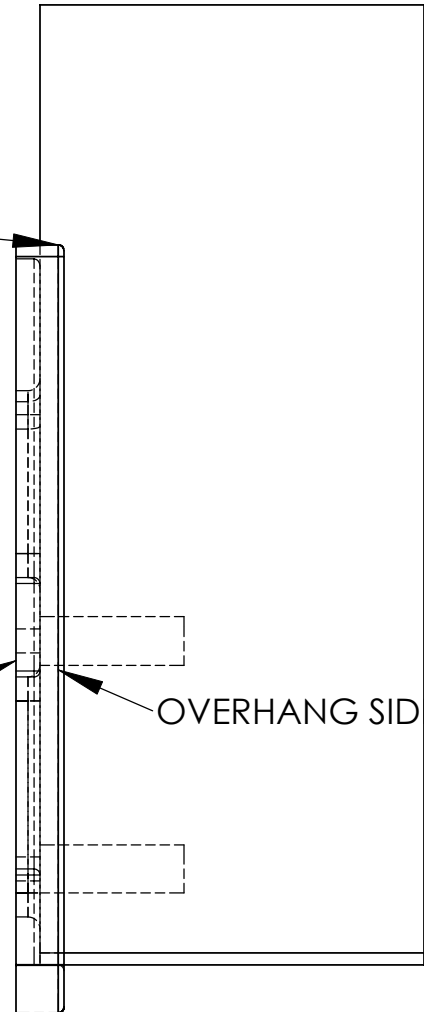

For Installation using locking pin option , drill two 3/8-1/2" diam. x 1-1/2" deep holes on end of substrate that align with holes on the INSERT (smaller drill diameter recommended when pin location is 1" from any edge or when drilling a brittle substrate). Attach pins to INSERT part and check for proper fit. Brush out drill dust and inject two-part epoxy. Align part to wall and set.

HINT: Use slow set epoxy. After setting part, set adjacent wall section. Place wedge between the flat side of the INSERT and adjacent wall section (this will hold the INSERT to the overhang side of the wall during cure).

TITLE: Typical INSERT installation using locking pins.		
SIZE A	DWG. NO. InsertDwg1	REV
SCALE: 1:5	WEIGHT: 1.74 lbs	SHEET 1 OF 1

PROPRIETARY AND CONFIDENTIAL THE INFORMATION CONTAINED IN THIS DRAWING IS THE SOLE PROPERTY OF INTELLICEPT. ANY REPRODUCTION IN PART OR AS A WHOLE WITHOUT THE WRITTEN PERMISSION OF INTELLICEPT IS PROHIBITED.	MATERIAL
	FINISH