

THE INFORMATION CONTAINED IN THIS DRAWING IS THE SOLE PROPERTY OF INTELLICEPT. ANY REPRODUCTION IN PART OR WHOLE WITHOUT THE WRITTEN PERMISSION OF INTELLICEPT IS PROHIBITED.

Product to be spaced on 30-36" centers and approximately 12-18" from the end points. Be sure that product is spaced evenly from end points.

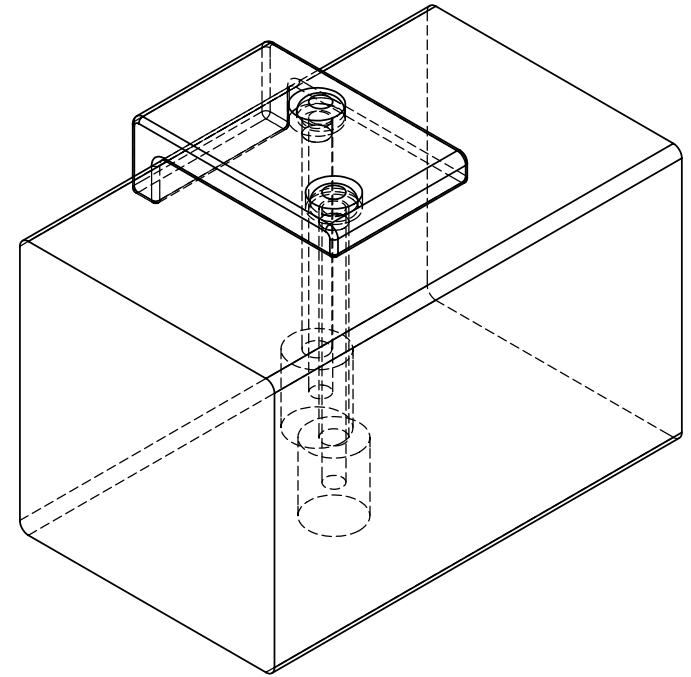

Step One:
Drill $\varnothing 5/16"$ thru holes for bolts.

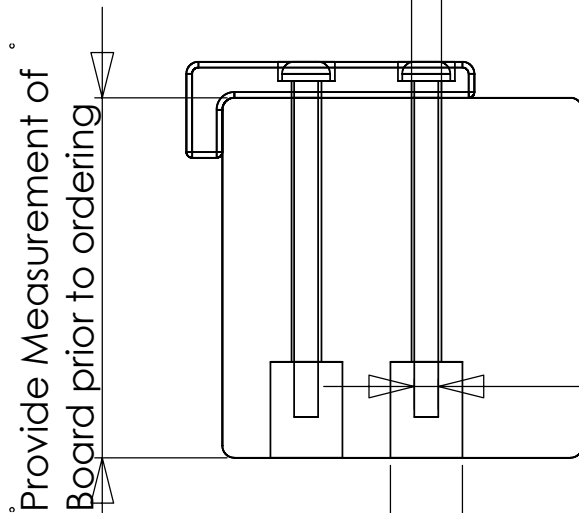

Provide Measurement of Board prior to ordering

Step Three:
Apply Loctite #262 Threadlocker to bolt (at the point where nut engages).
Drop bolts thru. Secure with washer and nut.

Step Two: Counterbore
Use wood auger/spade bit to counterbore hole so nut and washer set beneath surface.

INTELLICEPT SAN DIEGO, CALIFORNIA, U.S.A.			
Sample Carriage Assembly			
SIZE A	DWG. NO.		R
SCALE	CAD FILE:	SHEET	OF
8	2	1	