

THE INFORMATION CONTAINED IN THIS DRAWING IS THE SOLE PROPERTY OF INTELLECT. ANY REPRODUCTION IN PART OR WHOLE WITHOUT THE WRITTEN PERMISSION OF INTELLECT IS PROHIBITED.

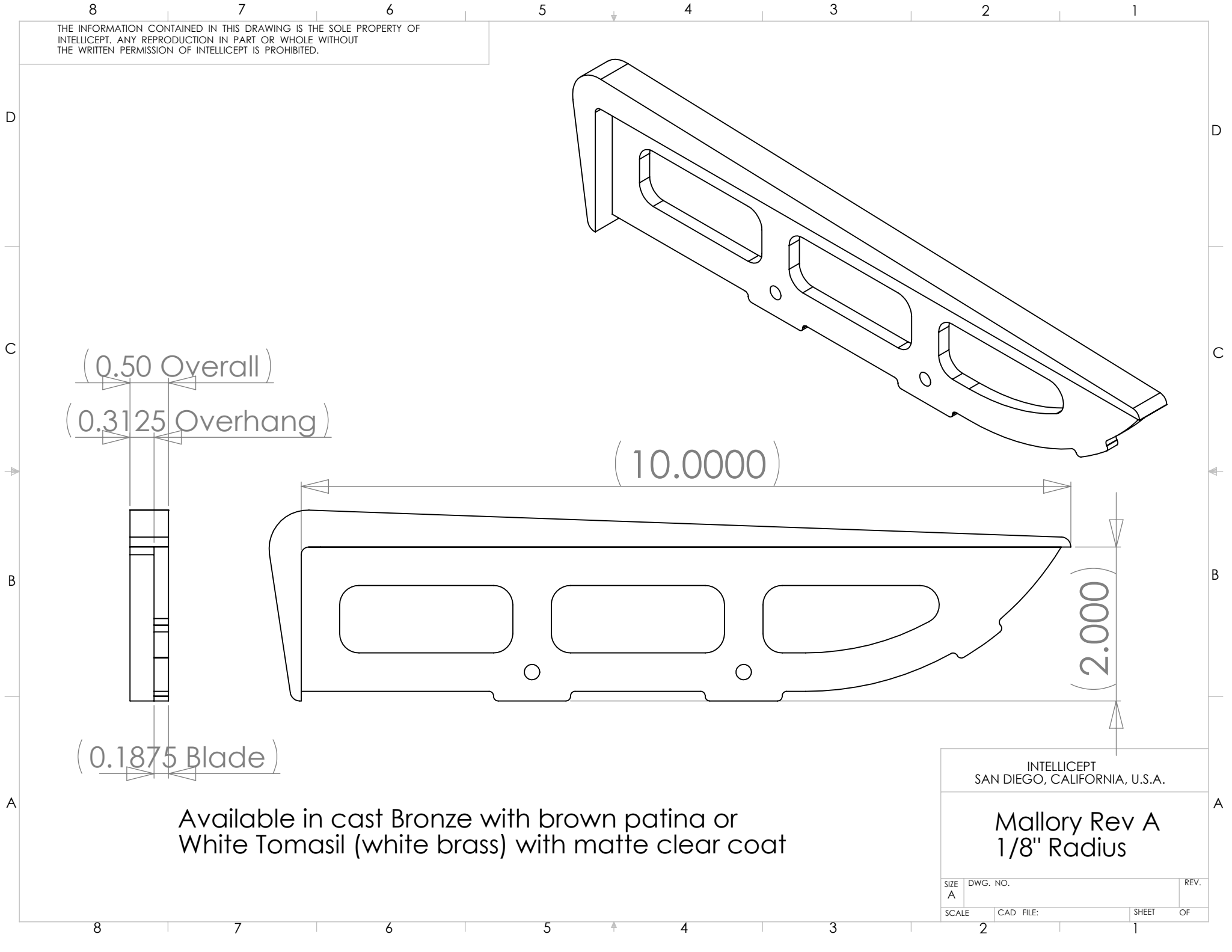

INTELLECT  
SAN DIEGO, CALIFORNIA, U.S.A.

Mallory Rev A  
1/8" Radius

SIZE A	DWG. NO.	REV.
SCALE	CAD FILE:	SHEET OF

8 7 6 5 4 3 2 1

THE INFORMATION CONTAINED IN THIS DRAWING IS THE SOLE PROPERTY OF INTELLECT. ANY REPRODUCTION IN PART OR WHOLE WITHOUT THE WRITTEN PERMISSION OF INTELLECT IS PROHIBITED.

D

D

C



C

B

(0.7500 Overall)

(0.2850) (0.2850)

(0.1800 Blade)

(7.5000)

(2.0000)

(R0.1000)

B

A

A

Available in cast Bronze with brown patina or White Tomasil (white brass) with matte clear coat

INTELLECT  
SAN DIEGO, CALIFORNIA, U.S.A.

San Francisco T  
for 1/8" Radius

SIZE A	DWG. NO.	REV.
SCALE	CAD FILE:	SHEET OF
2		1

8

7

6

5

4

3

2

1

8 7 6 5 4 3 2 1

THE INFORMATION CONTAINED IN THIS DRAWING IS THE SOLE PROPERTY OF INTELLECT. ANY REPRODUCTION IN PART OR WHOLE WITHOUT THE WRITTEN PERMISSION OF INTELLECT IS PROHIBITED.

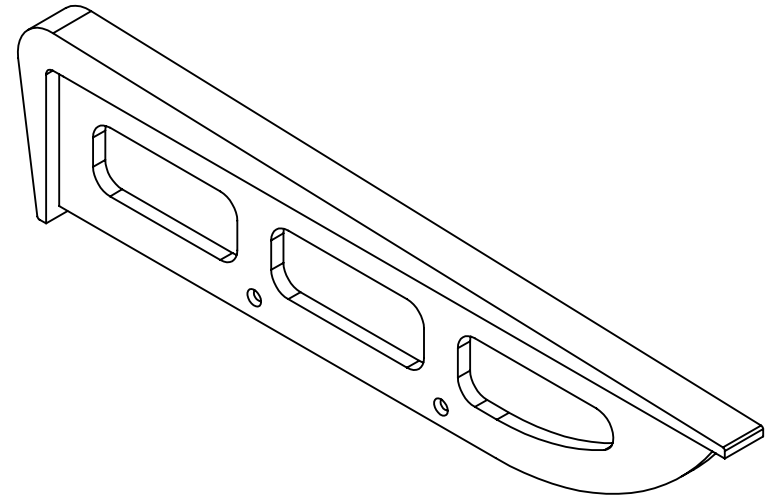

D

D

C

C

B

B

A

A

(0.5625 Overall)

(0.19 Overhang)

(0.19 Overhang)

(10.0000)

(2.00)

(0.18 Blade)

Available in cast Bronze with brown patina or  
White Tomasil (white brass) with matte clear coat

INTELLECT  
SAN DIEGO, CALIFORNIA, U.S.A.

Los Angeles T  
for 1/8" Radius

SIZE A	DWG. NO.	REV.
SCALE	CAD FILE:	SHEET OF

8

7

6

5

4

3

2

1

THE INFORMATION CONTAINED IN THIS DRAWING IS THE SOLE PROPERTY OF INTELLECT. ANY REPRODUCTION IN PART OR WHOLE WITHOUT THE WRITTEN PERMISSION OF INTELLECT IS PROHIBITED.

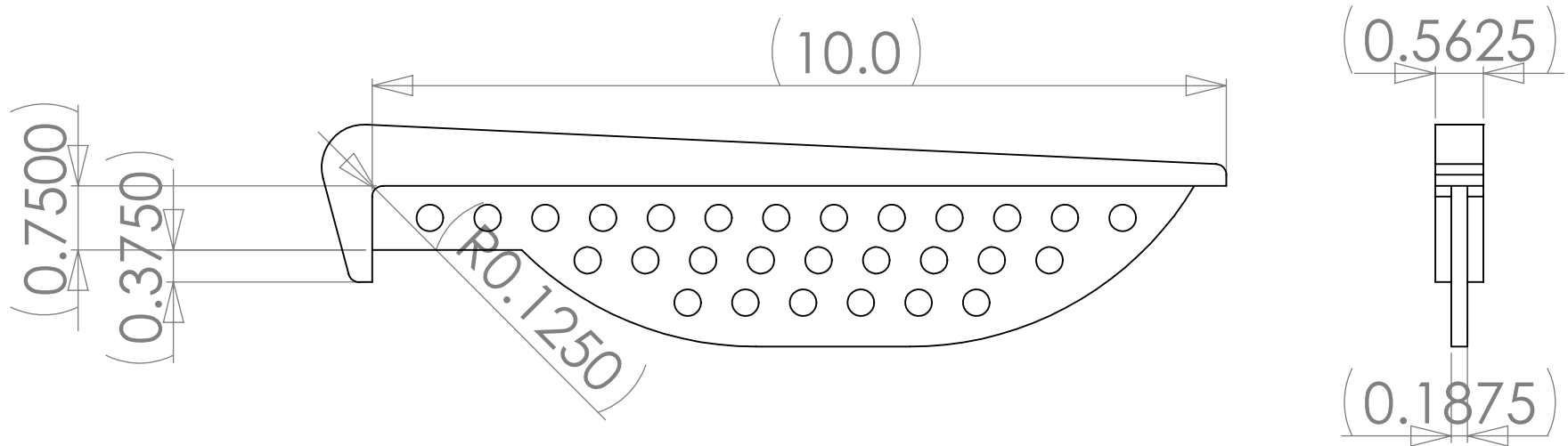

Available in cast Silicon Bronze with brown patina  
or White Tombasil (whitebrass) with matte clear coat

INTELLECT  
SAN DIEGO, CALIFORNIA, U.S.A.

Eugene T  
for 1/8" Radius

SIZE A	DWG. NO.	REV.
SCALE	CAD FILE:	SHEET OF
	2	1

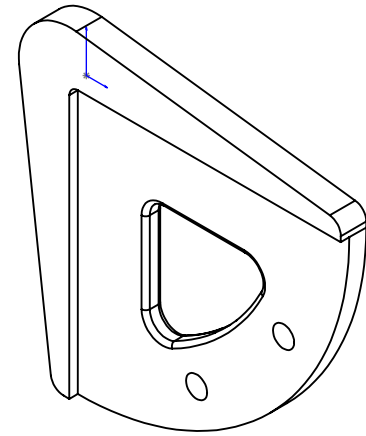
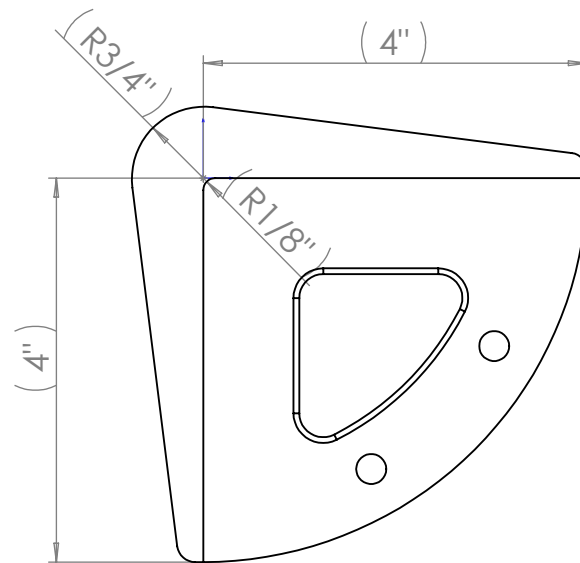
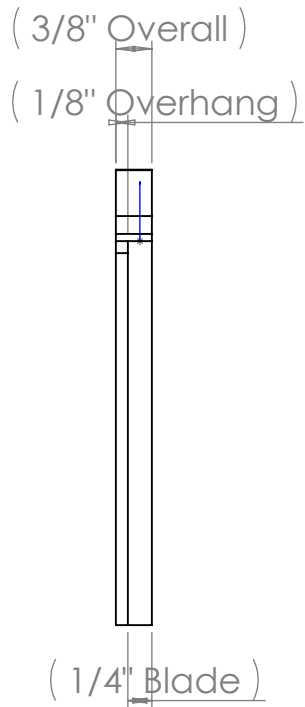

Available in cast Bronze with brown patina or  
 White Tombasil (white brass) with matte clear coat

UNLESS OTHERWISE SPECIFIED DIMENSIONS ARE IN INCHES	INTELLICEPT, CA USA		
	Mayo Design 4" Radius Insert		
	MATERIAL Cast Silicon Bronze	SCALE	CAD FILE:
FINISH Brown Patina			SHEET

THE INFORMATION CONTAINED IN THIS DRAWING IS THE SOLE PROPERTY OF Intellicept. ANY REPRODUCTION IN PART OR WHOLE WITHOUT THE WRITTEN PERMISSION OF Intellicept IS PROHIBITED.

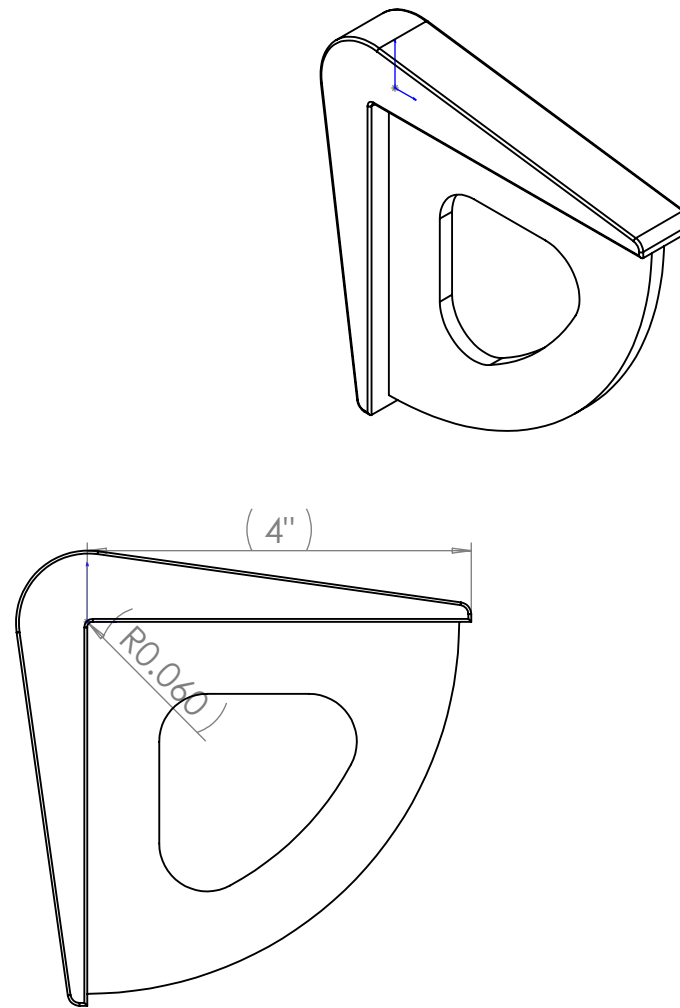
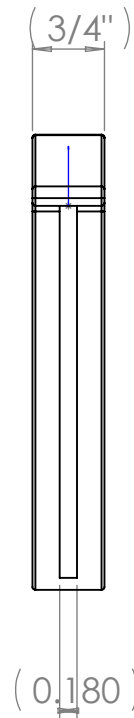

Available in Cast White Tomabsil with matte clear coat or Silicone Bronze with brown patina finish.

UNLESS OTHERWISE SPECIFIED DIMENSIONS ARE IN INCHES		INTELLICEPT, CA USA	
MATERIAL		Firvida T for 1/8" Radius	
FINISH			
SCALE	CAD FILE:	SHEET	

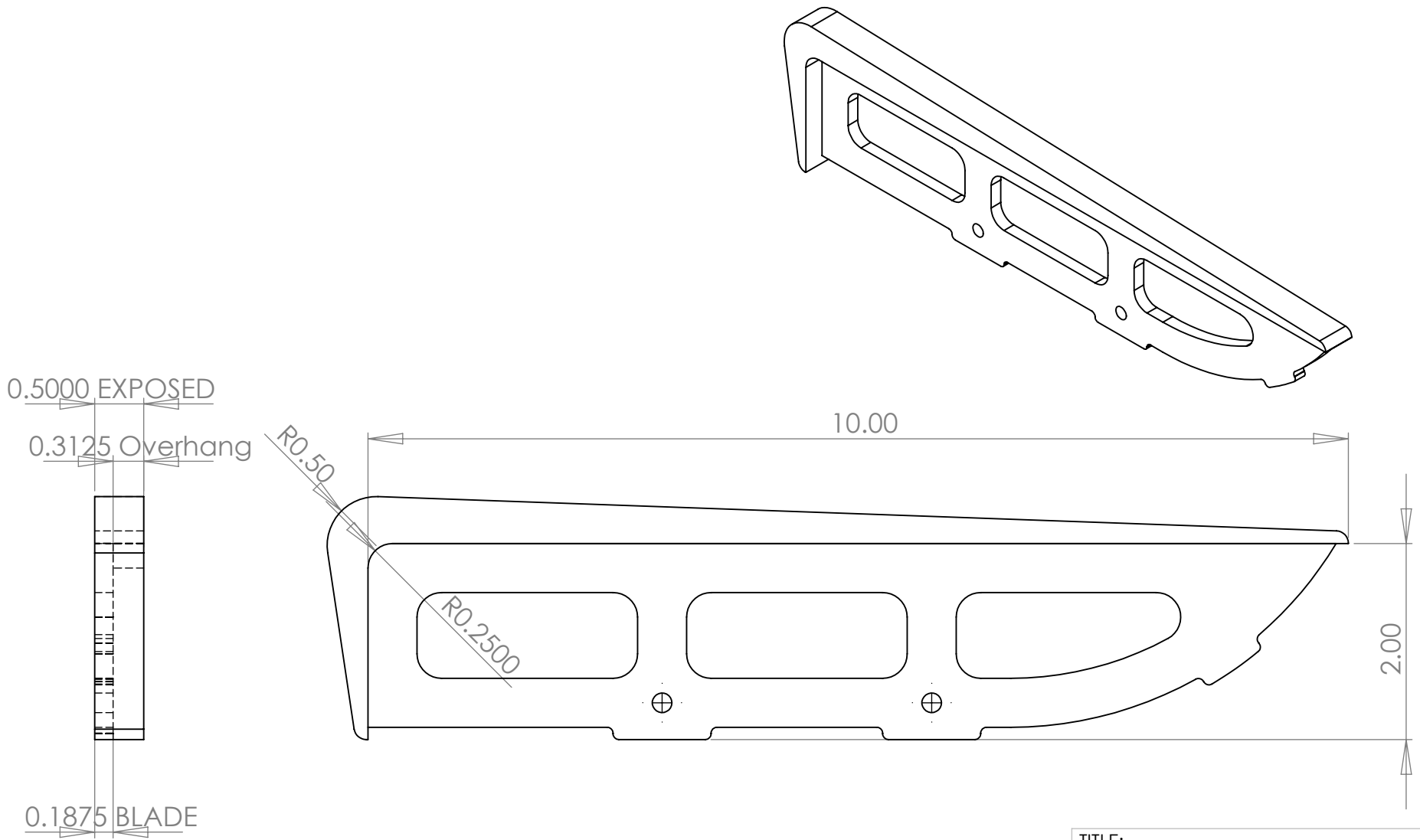

Available in Cast Bronze with Brown Patina Finish  
 or White Tombasil (white Brass) with Matte Clear

TITLE:		
lowa Insert for 1/4" Radius		
SIZE	DWG. NO.	REV
A	lowacutsh	
SCALE: 1:1.5	WEIGHT: 1.74 lbs	SHEET 1 OF 1

PROPRIETARY AND CONFIDENTIAL  
 THE INFORMATION CONTAINED IN THIS  
 DRAWING IS THE SOLE PROPERTY OF  
 INTELLICEPT. ANY REPRODUCTION IN  
 PART OR AS A WHOLE WITHOUT THE  
 WRITTEN PERMISSION OF  
 INTELLICEPT IS PROHIBITED.

MATERIAL

FINISH

THE INFORMATION CONTAINED IN THIS DRAWING IS THE SOLE PROPERTY OF INTELLECT. ANY REPRODUCTION IN PART OR WHOLE WITHOUT THE WRITTEN PERMISSION OF INTELLECT IS PROHIBITED.

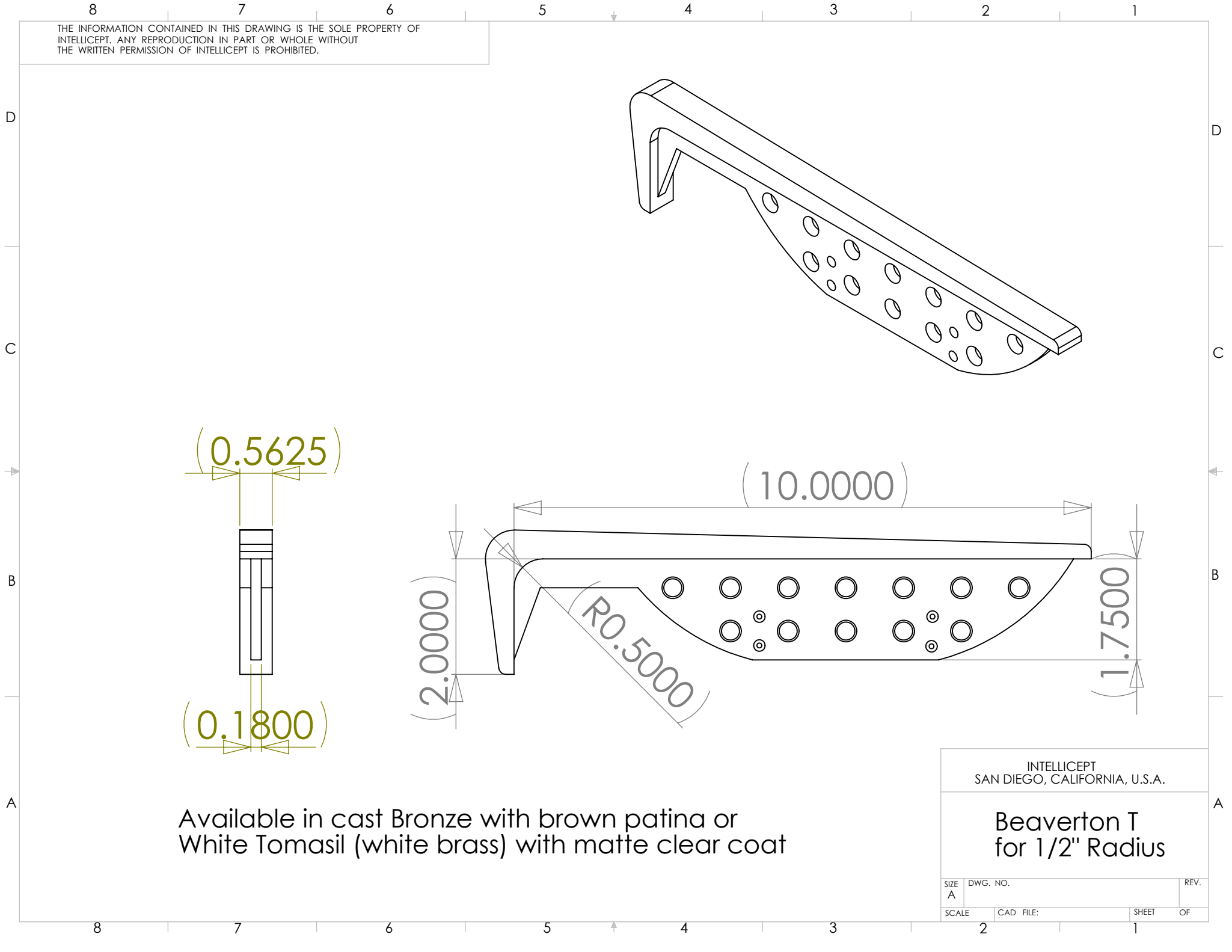

Available in cast Bronze with brown patina or White Tomasil (white brass) with matte clear coat

INTELLECT  
SAN DIEGO, CALIFORNIA, U.S.A.

Beaverton T  
for 1/2" Radius

SIZE A	DWG. NO.	REV.
SCALE	CAD FILE:	SHEET OF



8 7 6 5 4 3 2 1

THE INFORMATION CONTAINED IN THIS DRAWING IS THE SOLE PROPERTY OF INTELLECT. ANY REPRODUCTION IN PART OR WHOLE WITHOUT THE WRITTEN PERMISSION OF INTELLECT IS PROHIBITED.

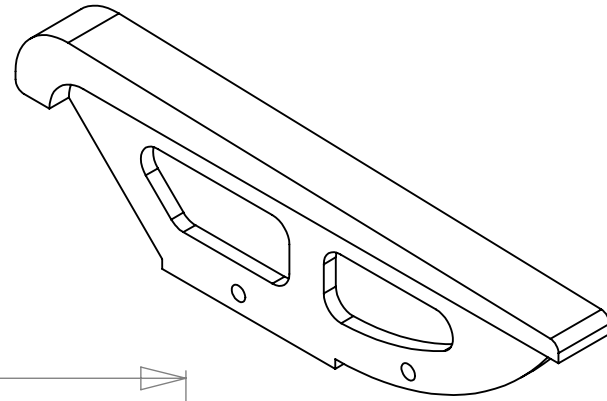
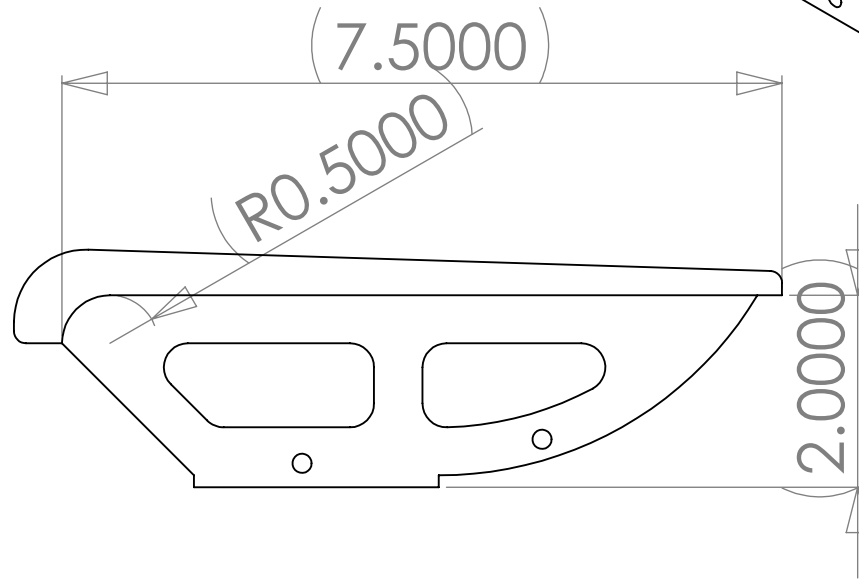
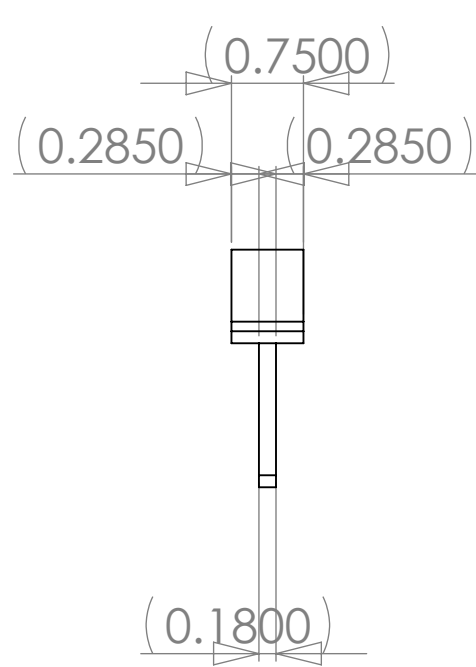

Available in cast Bronze with brown patina or White Tomasil (white brass) with matte clear coat

INTELLECT  
SAN DIEGO, CALIFORNIA, U.S.A.

San Dieguito T  
for 1/2" Radius

SIZE A	DWG. NO.	REV.
SCALE	CAD FILE:	SHEET OF
	2	1

THE INFORMATION CONTAINED IN THIS DRAWING IS THE SOLE PROPERTY OF INTELLECT. ANY REPRODUCTION IN PART OR WHOLE WITHOUT THE WRITTEN PERMISSION OF INTELLECT IS PROHIBITED.

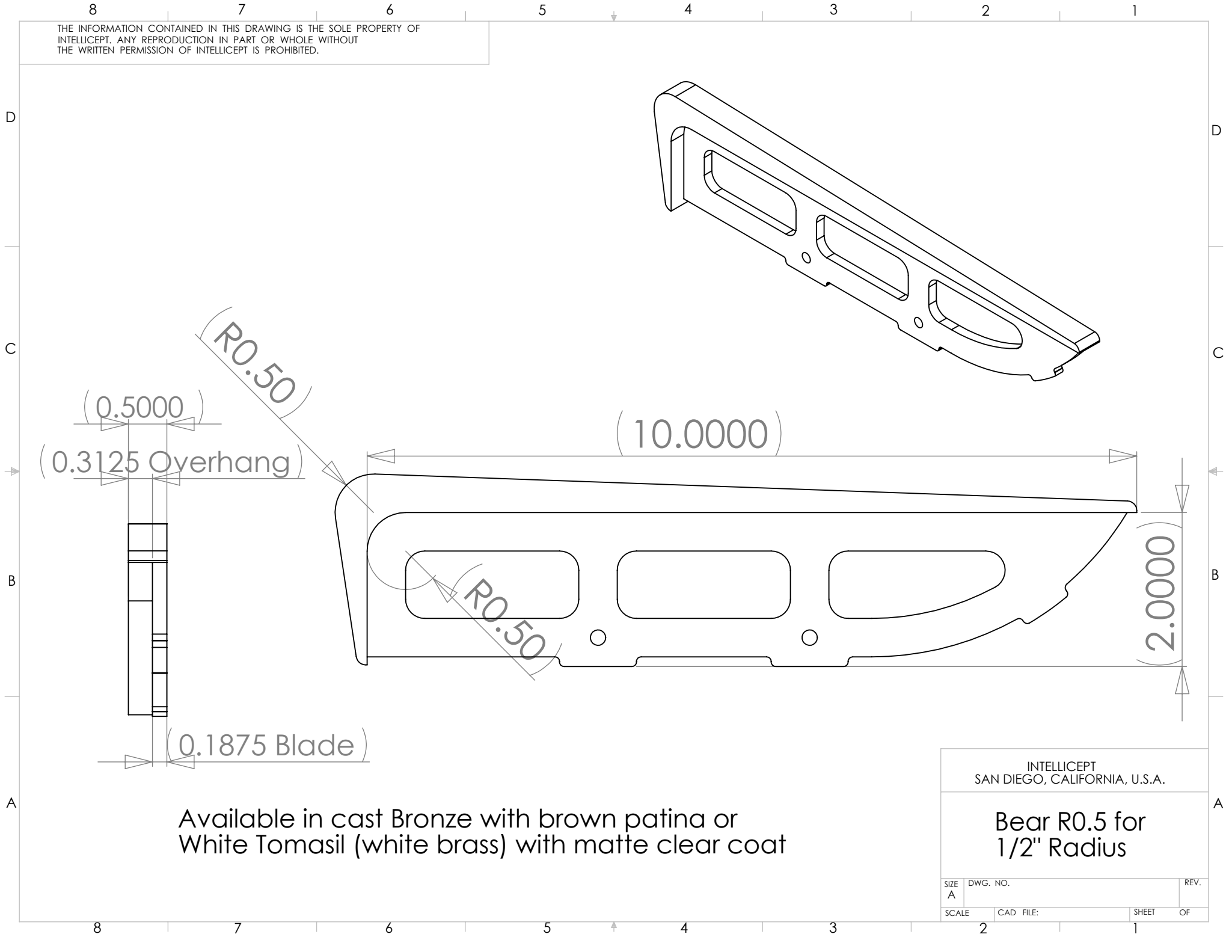

INTELLECT  
SAN DIEGO, CALIFORNIA, U.S.A.

### Bear R0.5 for 1/2" Radius

SIZE A	DWG. NO.	REV.
SCALE	CAD FILE:	SHEET OF

2 1

8 7 6 5 4 3 2 1

THE INFORMATION CONTAINED IN THIS DRAWING IS THE SOLE PROPERTY OF INTELLECT. ANY REPRODUCTION IN PART OR WHOLE WITHOUT THE WRITTEN PERMISSION OF INTELLECT IS PROHIBITED.

D  
C  
B  
A

D  
C  
B  
A

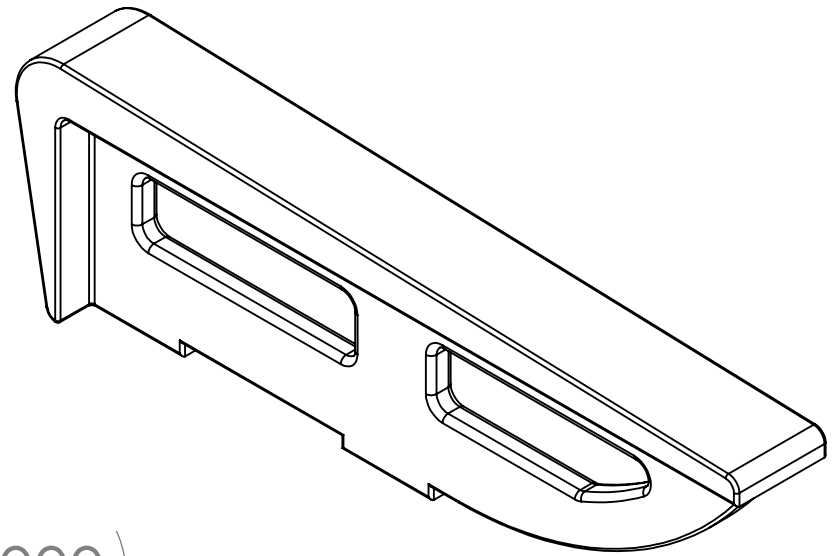

(1.0 Overall)

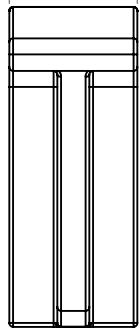

(0.25 BLADE)

(7.5000)

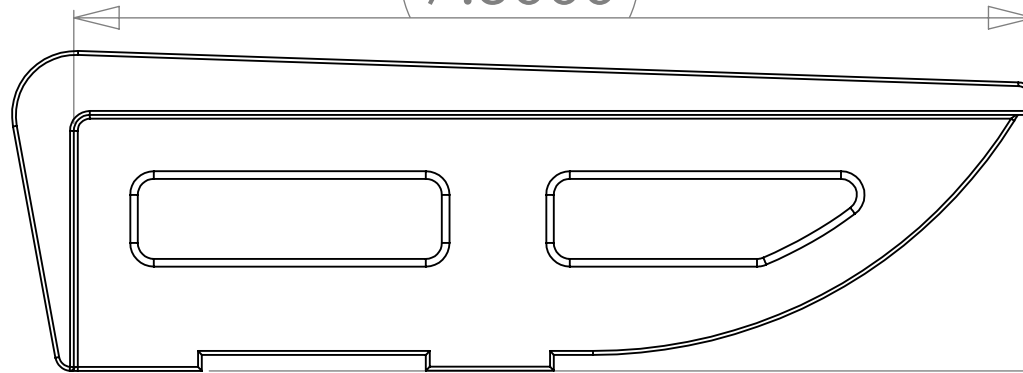

(2.0000)

Available in cast Bronze with brown patina or White Tomasil (white brass) with matte clear coat

INTELLECT  
SAN DIEGO, CALIFORNIA, U.S.A.

Arlington T  
for 1/8" Radius

SIZE A	DWG. NO.	REV.
SCALE	CAD FILE:	SHEET OF

THE INFORMATION CONTAINED IN THIS DRAWING IS THE SOLE PROPERTY OF INTELICEPT. ANY REPRODUCTION IN PART OR WHOLE WITHOUT THE WRITTEN PERMISSION OF INTELICEPT IS PROHIBITED.

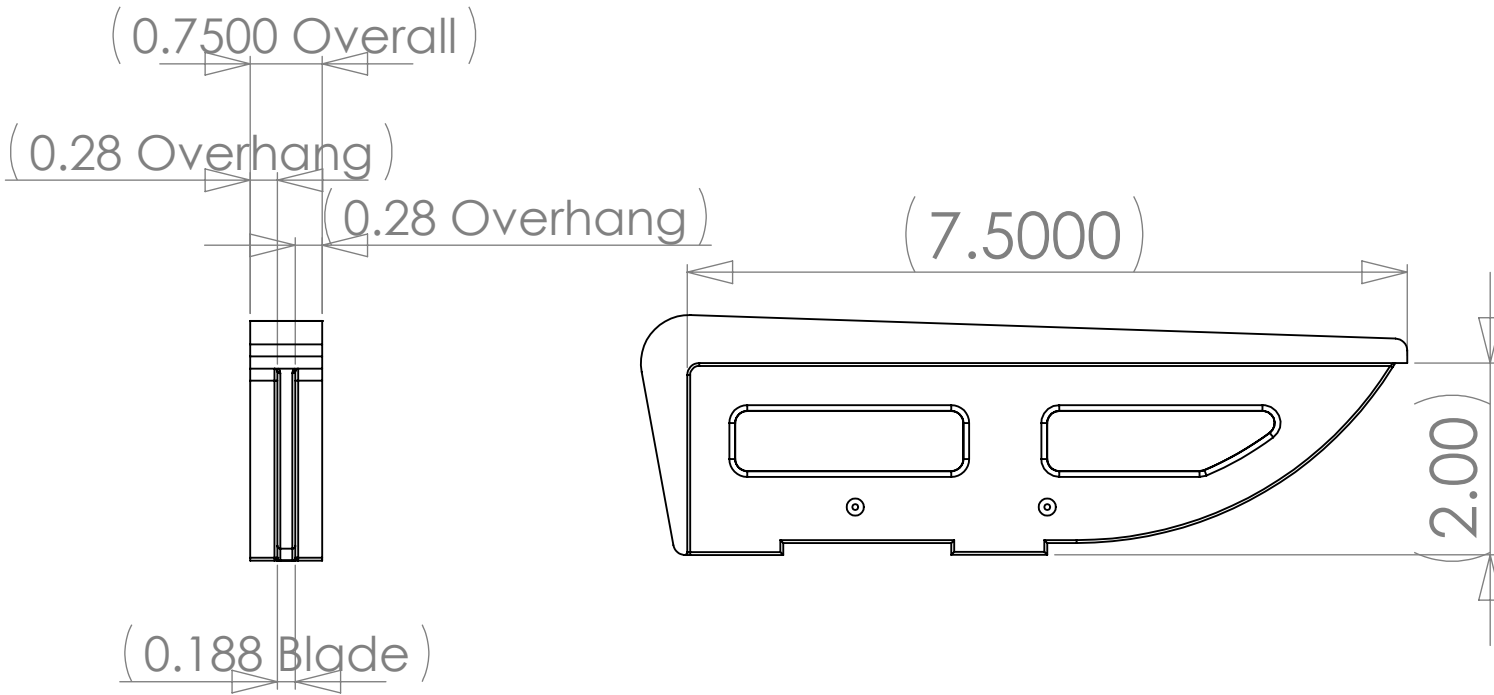
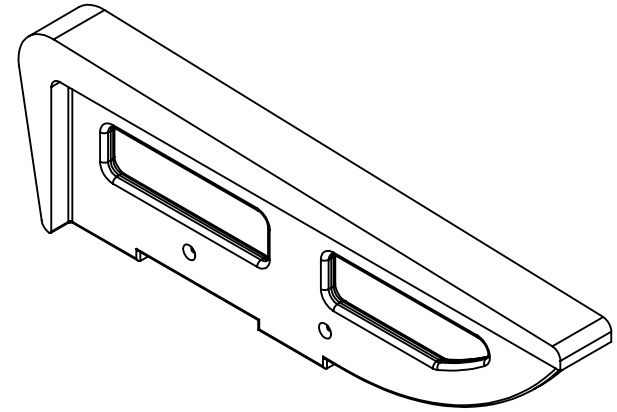

Available in cast Bronze with brown patina or White Tomasil (white brass) with matte clear coat  
 Set part into joint. Use locking pins wherever possible

INTELICEPT  
 SAN DIEGO, CALIFORNIA, U.S.A.

Potomac T  
 1/8" Radius

SIZE A	DWG. NO.	REV.
SCALE	CAD FILE:	SHEET OF

2 1

THE INFORMATION CONTAINED IN THIS DRAWING IS THE SOLE PROPERTY OF INTELLICEPT. ANY REPRODUCTION IN PART OR WHOLE WITHOUT THE WRITTEN PERMISSION OF INTELLICEPT IS PROHIBITED.

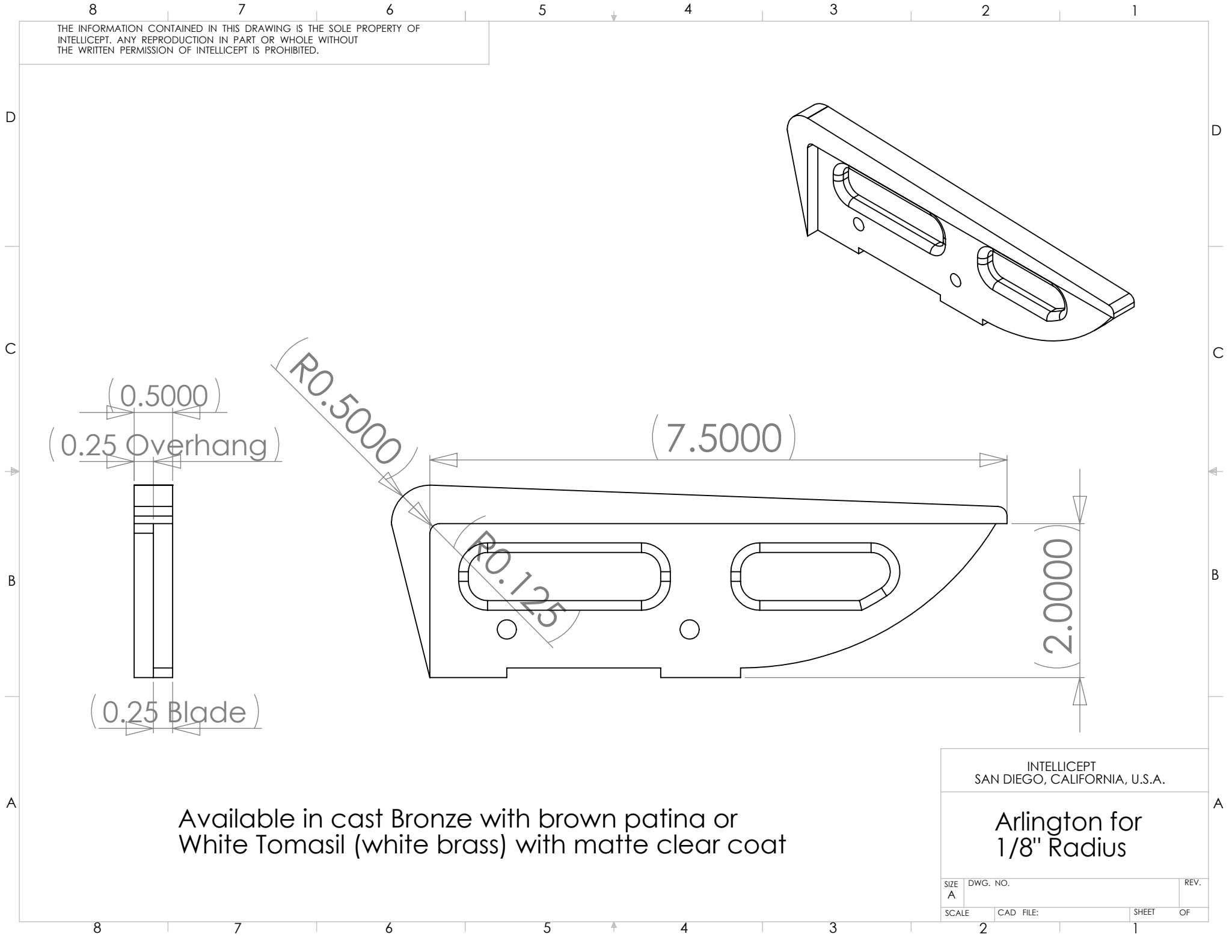

Available in cast Bronze with brown patina or  
White Tomasil (white brass) with matte clear coat

INTELLICEPT  
SAN DIEGO, CALIFORNIA, U.S.A.

Arlington for  
1/8" Radius

SIZE A	DWG. NO.	REV.
SCALE	CAD FILE:	SHEET OF
	2	1

THE INFORMATION CONTAINED IN THIS DRAWING IS THE SOLE PROPERTY OF INTELLECT. ANY REPRODUCTION IN PART OR WHOLE WITHOUT THE WRITTEN PERMISSION OF INTELLECT IS PROHIBITED.

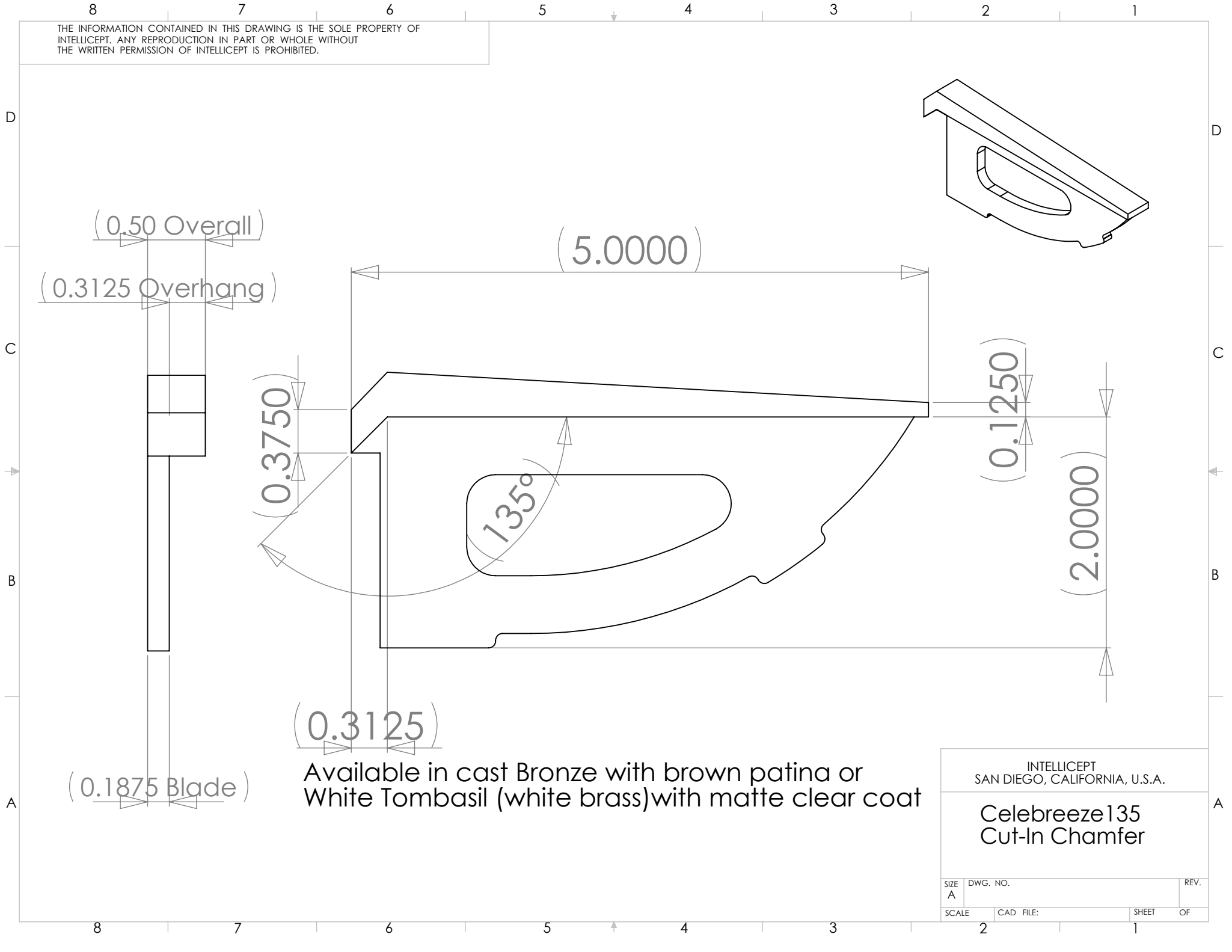

(0.50 Overall)  
(0.3125 Overhang)

(5.0000)

(0.3750)

(0.1250)

(2.0000)

135°

(0.3125)

(0.1875 Blade)

Available in cast Bronze with brown patina or  
White Tombasil (white brass)with matte clear coat

INTELLECT SAN DIEGO, CALIFORNIA, U.S.A.			
Celebreeze 135 Cut-In Chamfer			
SIZE A	DWG. NO.	REV.	
SCALE	CAD FILE:	SHEET	OF

8 7 6 5 4 3 2 1

THE INFORMATION CONTAINED IN THIS DRAWING IS THE SOLE PROPERTY OF INTELLECT. ANY REPRODUCTION IN PART OR WHOLE WITHOUT THE WRITTEN PERMISSION OF INTELLECT IS PROHIBITED.

D  
C  
B  
A

D  
C  
B  
A

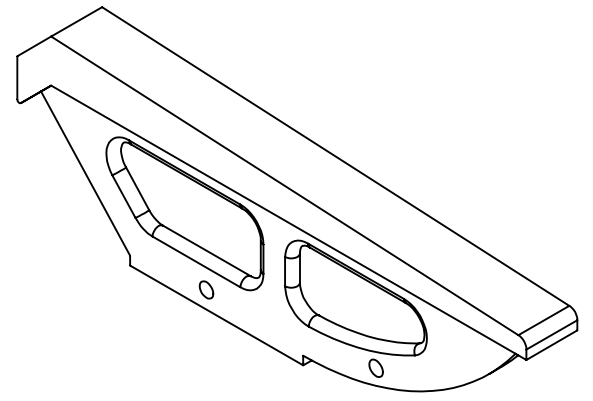

(0.7500 Overall)

(7.5000)

(2.0000)

(0.1800 Blade)

(0.5000)

(0.2850 Overhang)

(0.2850 Overhang)



Available in cast Bronze with brown patina or White Tomasil (white brass) with matte clear coat

INTELLECT SAN DIEGO, CALIFORNIA, U.S.A.			
<b>San Marcos T for Chamfer</b>			
SIZE A	DWG. NO.	REV.	
SCALE	CAD FILE:	SHEET	OF
		1	1

8 7 6 5 4 3 2 1

0.4375 Overall  
0.2500 Overhang



0.1875 Blade

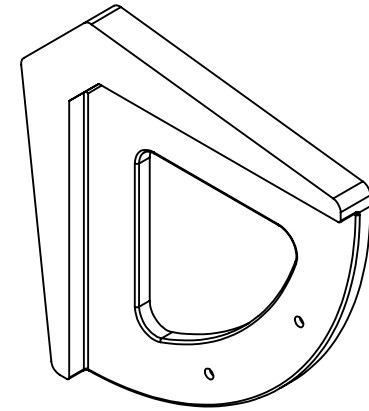
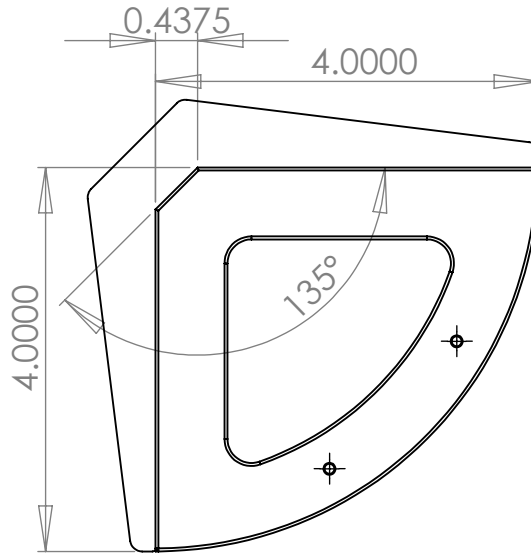

Available in cast Bronze with brown patina or  
White Tombasil (white brass) with matte clear coat

TITLE:		
Conley Insert for 1/2" Chamfer		
SIZE	DWG. NO.	REV
<b>A</b>	Conley135dim	
SCALE: 1:2	WEIGHT: 1.74 lbs	SHEET 1 OF 1

PROPRIETARY AND CONFIDENTIAL  
THE INFORMATION CONTAINED IN THIS  
DRAWING IS THE SOLE PROPERTY OF  
INTELLICEPT. ANY REPRODUCTION IN  
PART OR AS A WHOLE WITHOUT THE  
WRITTEN PERMISSION OF  
INTELLICEPT IS PROHIBITED.

MATERIAL  
  
FINISH



THE INFORMATION CONTAINED IN THIS DRAWING IS THE SOLE PROPERTY OF INTELLECT. ANY REPRODUCTION IN PART OR WHOLE WITHOUT THE WRITTEN PERMISSION OF INTELLECT IS PROHIBITED.

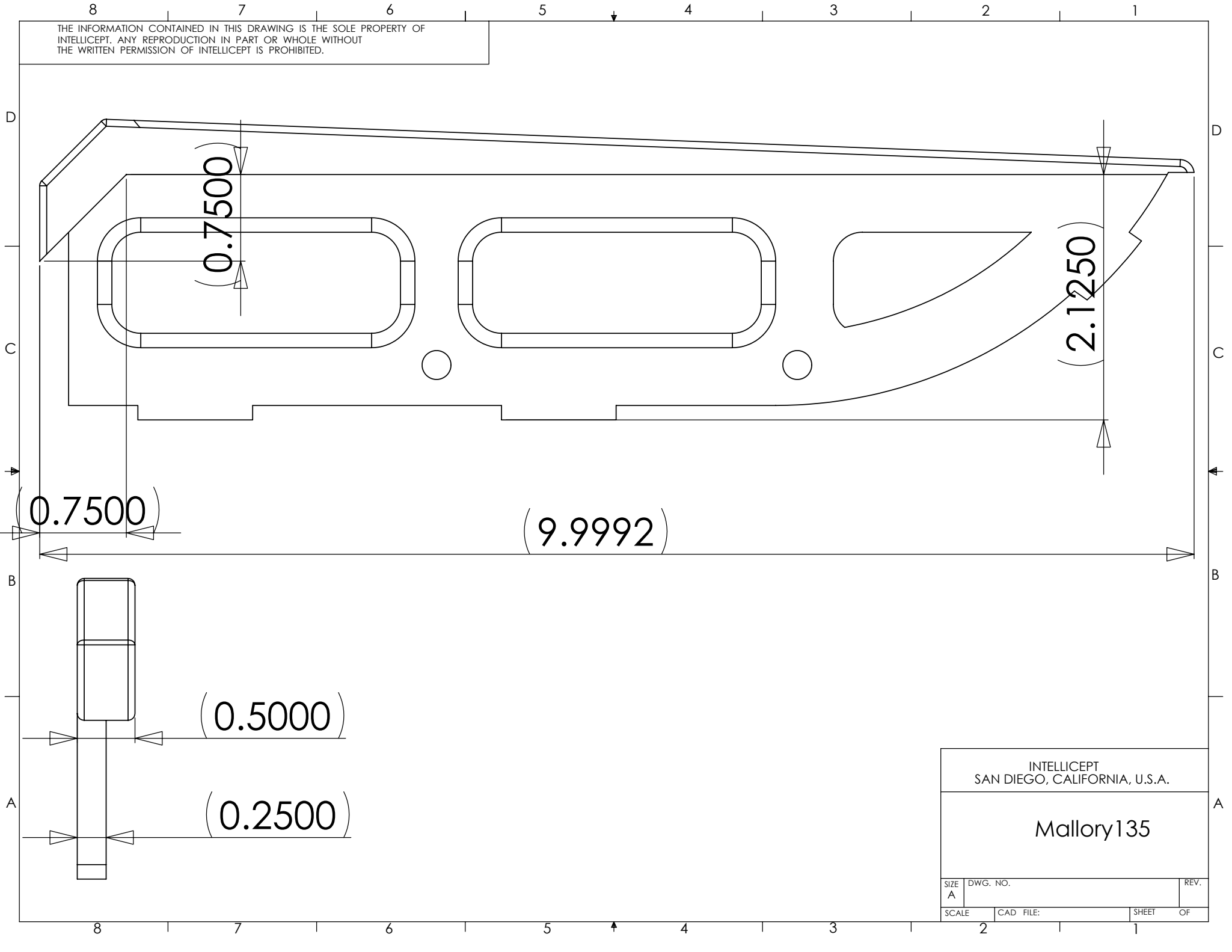

INTELLECT SAN DIEGO, CALIFORNIA, U.S.A.			
Mallory135			
SIZE A	DWG. NO.	REV.	
SCALE	CAD FILE:	SHEET	OF

THE INFORMATION CONTAINED IN THIS DRAWING IS THE SOLE PROPERTY OF INTELLICEPT. ANY REPRODUCTION IN PART OR WHOLE WITHOUT THE WRITTEN PERMISSION OF INTELLICEPT IS PROHIBITED.

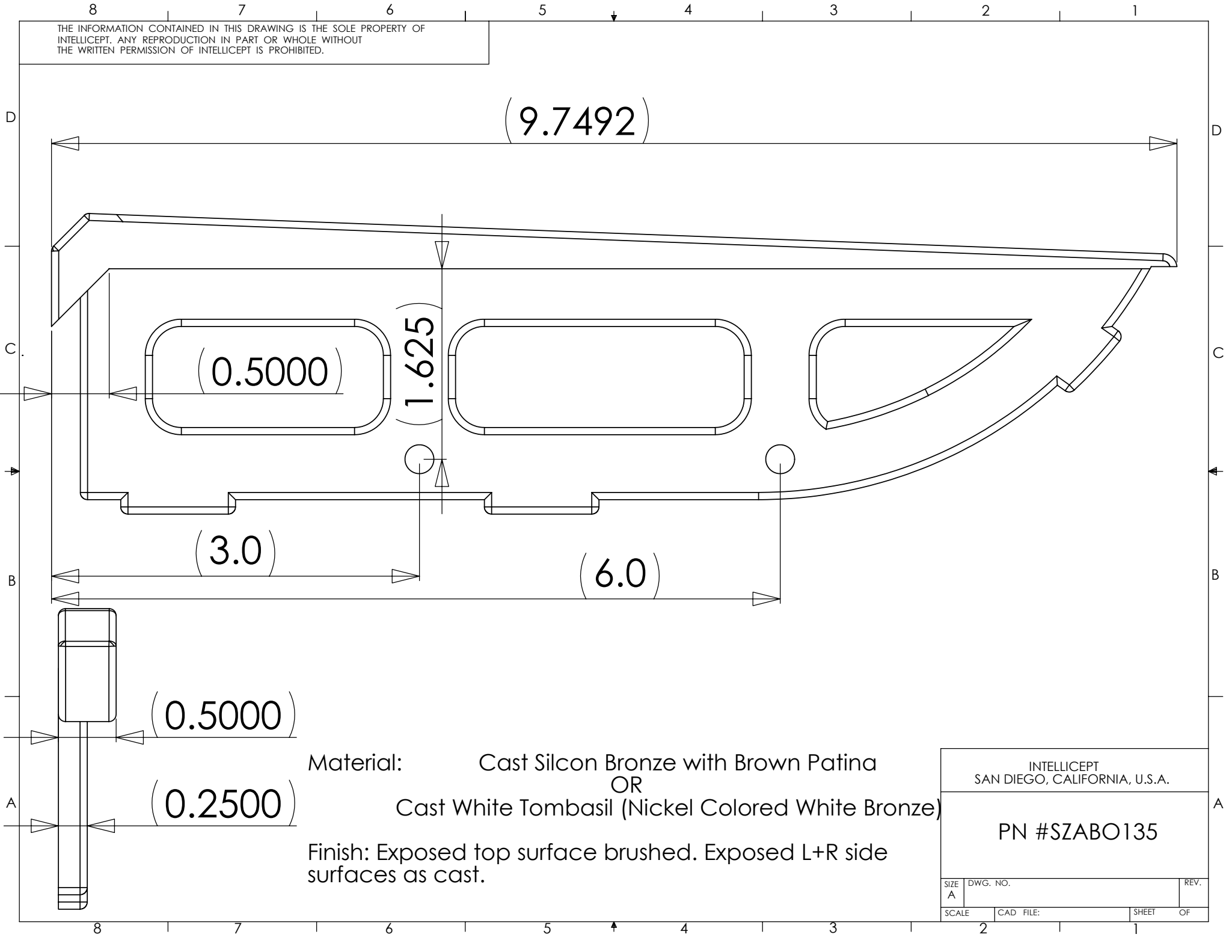

Material: Cast Silcon Bronze with Brown Patina  
OR  
Cast White Tombasil (Nickel Colored White Bronze)

Finish: Exposed top surface brushed. Exposed L+R side surfaces as cast.

INTELLICEPT SAN DIEGO, CALIFORNIA, U.S.A.			
PN #SZABO135			
SIZE A	DWG. NO.	REV.	
SCALE	CAD FILE:	SHEET	OF

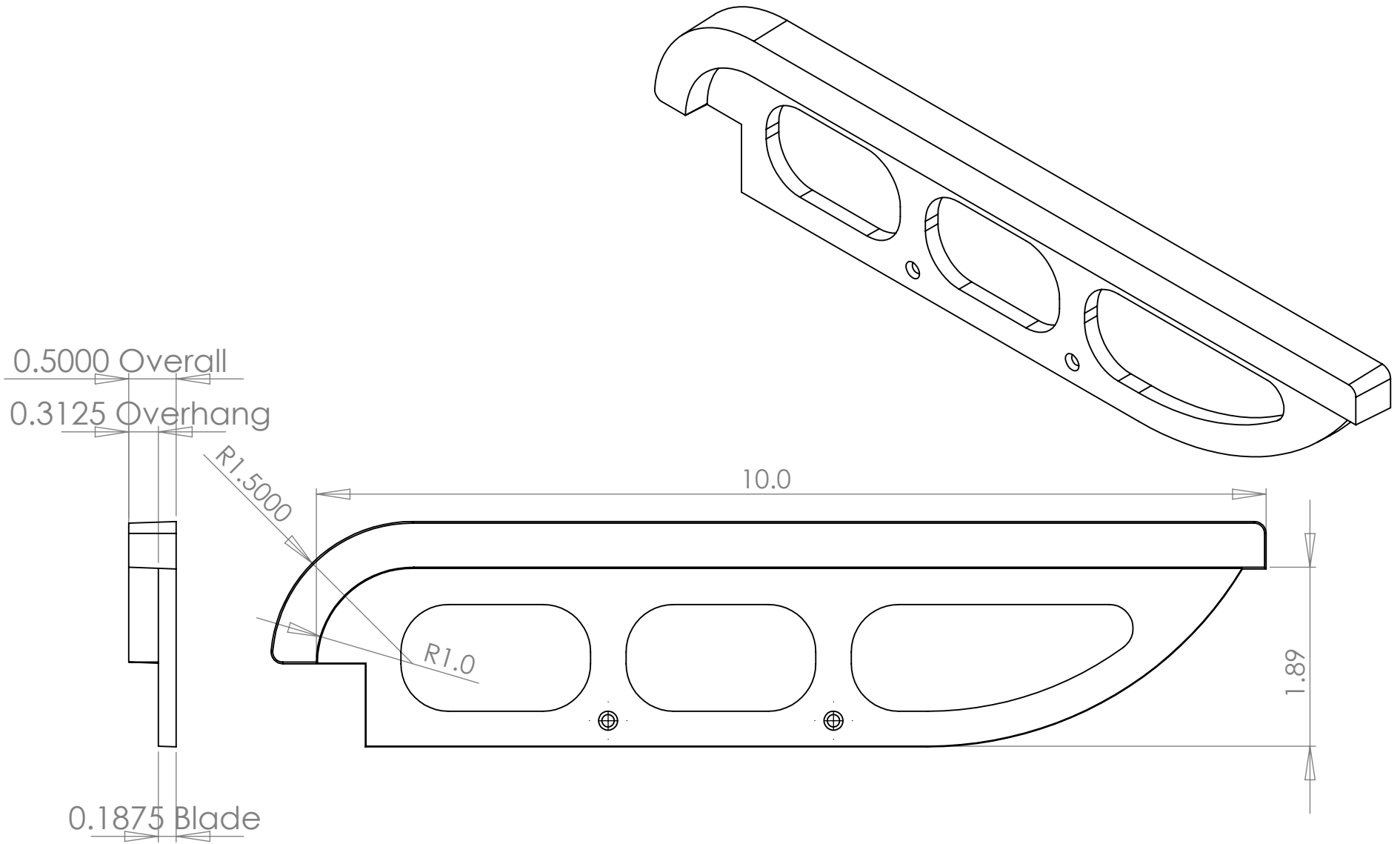

Available in cast Bronze with brown patina or  
 White Tombasil (white brass) with matte clear coat

TITLE:		
Pooler1.0 for 1" Radius		
SIZE	DWG. NO.	REV
A	Pooler	
SCALE: 1:2	WEIGHT: 1.74 lbs	SHEET 1 OF 1

PROPRIETARY AND CONFIDENTIAL  
 THE INFORMATION CONTAINED IN THIS  
 DRAWING IS THE SOLE PROPERTY OF  
 INTELLICEPT. ANY REPRODUCTION IN  
 PART OR AS A WHOLE WITHOUT THE  
 WRITTEN PERMISSION OF  
 INTELLICEPT IS PROHIBITED.

MATERIAL  
  
 FINISH

THE INFORMATION CONTAINED IN THIS DRAWING IS THE SOLE PROPERTY OF INTELLECT. ANY REPRODUCTION IN PART OR WHOLE WITHOUT THE WRITTEN PERMISSION OF INTELLECT IS PROHIBITED.

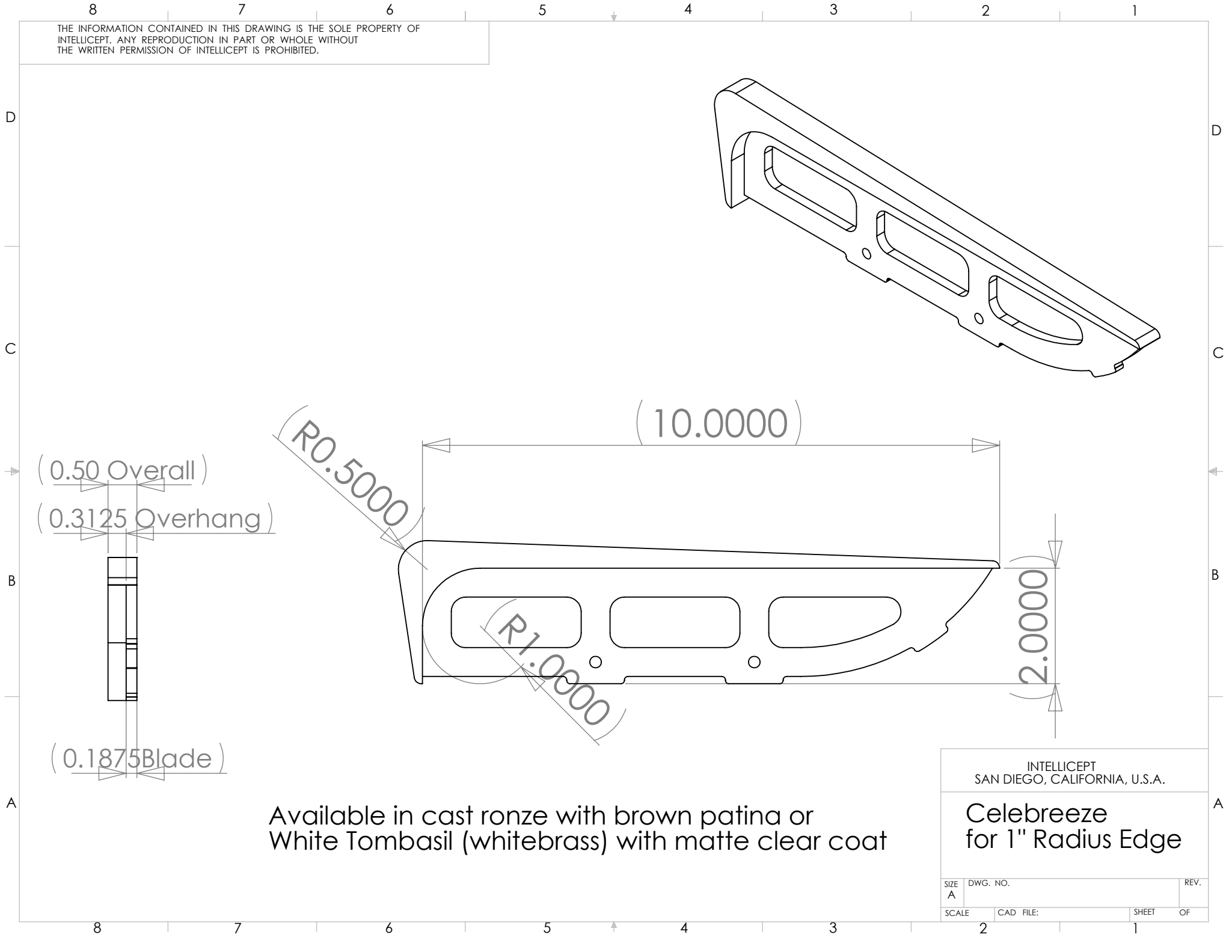

Available in cast bronze with brown patina or  
White Tombasil (whitebrass) with matte clear coat

INTELLECT SAN DIEGO, CALIFORNIA, U.S.A.			
Celebreeze for 1" Radius Edge			
SIZE A	DWG. NO.	REV.	
SCALE	CAD FILE:	SHEET	OF

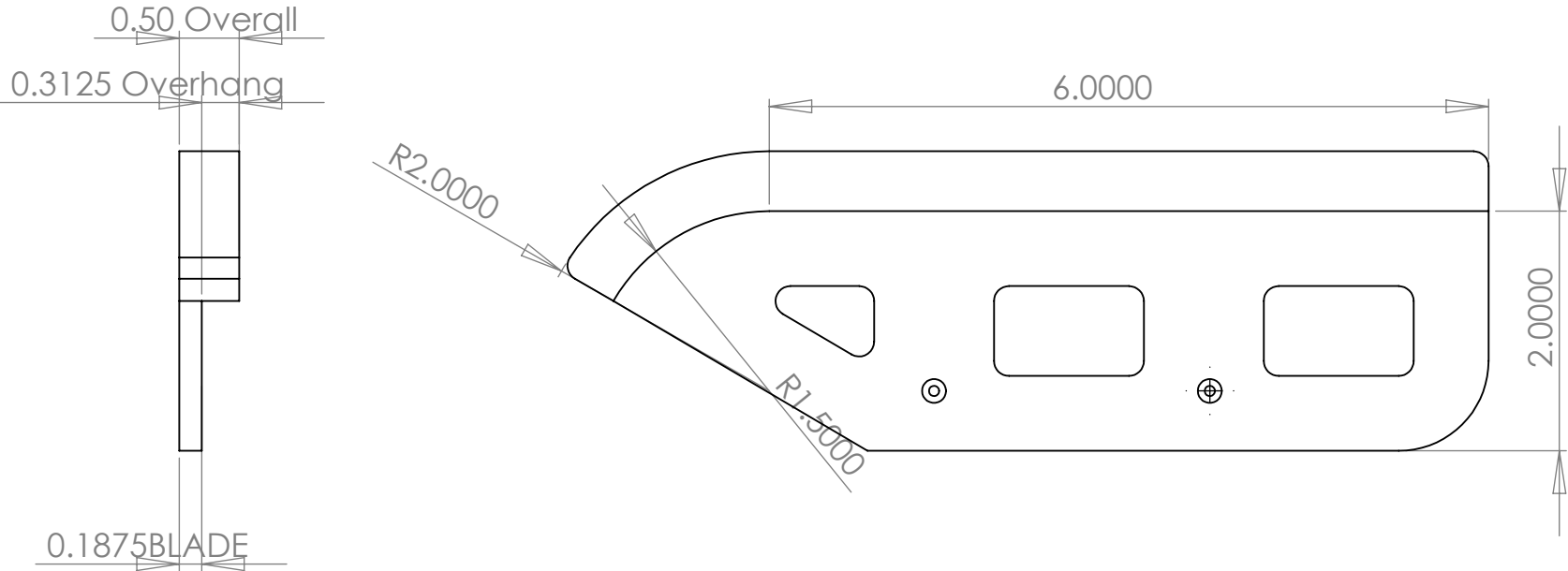
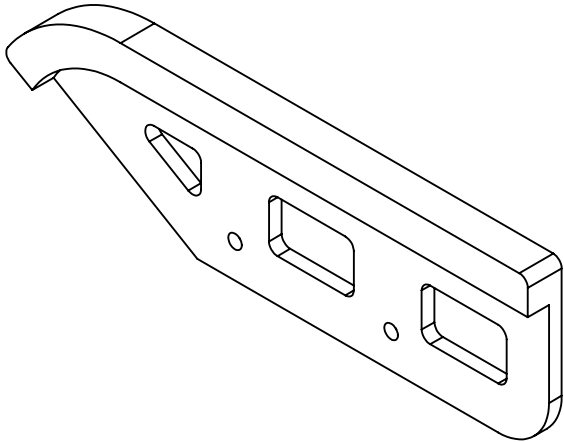

Available in cast Bronze with brown patina or White Tombasil (white brass) with matte clear coat

TITLE:		
Meyer R1.5 Insert for 1-1/2" Radius Bullnose		
SIZE	DWG. NO.	REV
A	MeyerR1-5	
WEIGHT: 1.74 lbs		SHEET 1 OF 1

PROPRIETARY AND CONFIDENTIAL  
THE INFORMATION CONTAINED IN THIS  
DRAWING IS THE SOLE PROPERTY OF  
INTELLICEPT. ANY REPRODUCTION IN  
PART OR AS A WHOLE WITHOUT THE  
WRITTEN PERMISSION OF  
INTELLICEPT IS PROHIBITED.

MATERIAL  
FINISH

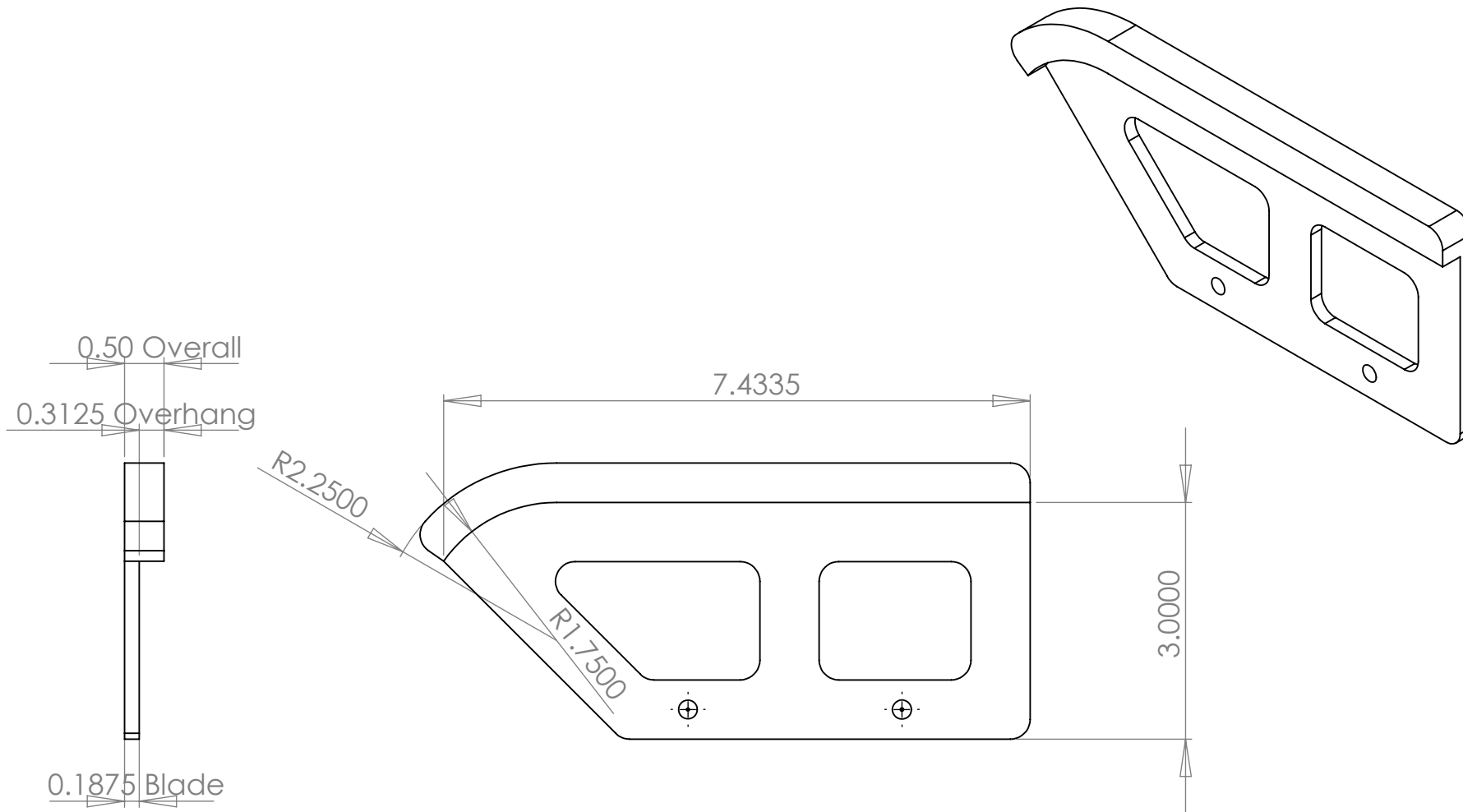

Available in cast Bronze with brown patina or  
White Tombasil (white brass) with matte clear coat

TITLE: Palms R1.75 Insert for 1-3/4" radius bullnose		
SIZE <b>A</b>	DWG. NO. <b>PalmR1-75</b>	REV
WEIGHT: 1.74 lbs		SHEET 1 OF 1

PROPRIETARY AND CONFIDENTIAL  
THE INFORMATION CONTAINED IN THIS  
DRAWING IS THE SOLE PROPERTY OF  
INTELLICEPT. ANY REPRODUCTION IN  
PART OR AS A WHOLE WITHOUT THE  
WRITTEN PERMISSION OF  
INTELLICEPT IS PROHIBITED.

MATERIAL  
  
FINISH

0.5000 Overall  
0.3125 Overhang

0.1875 Blade

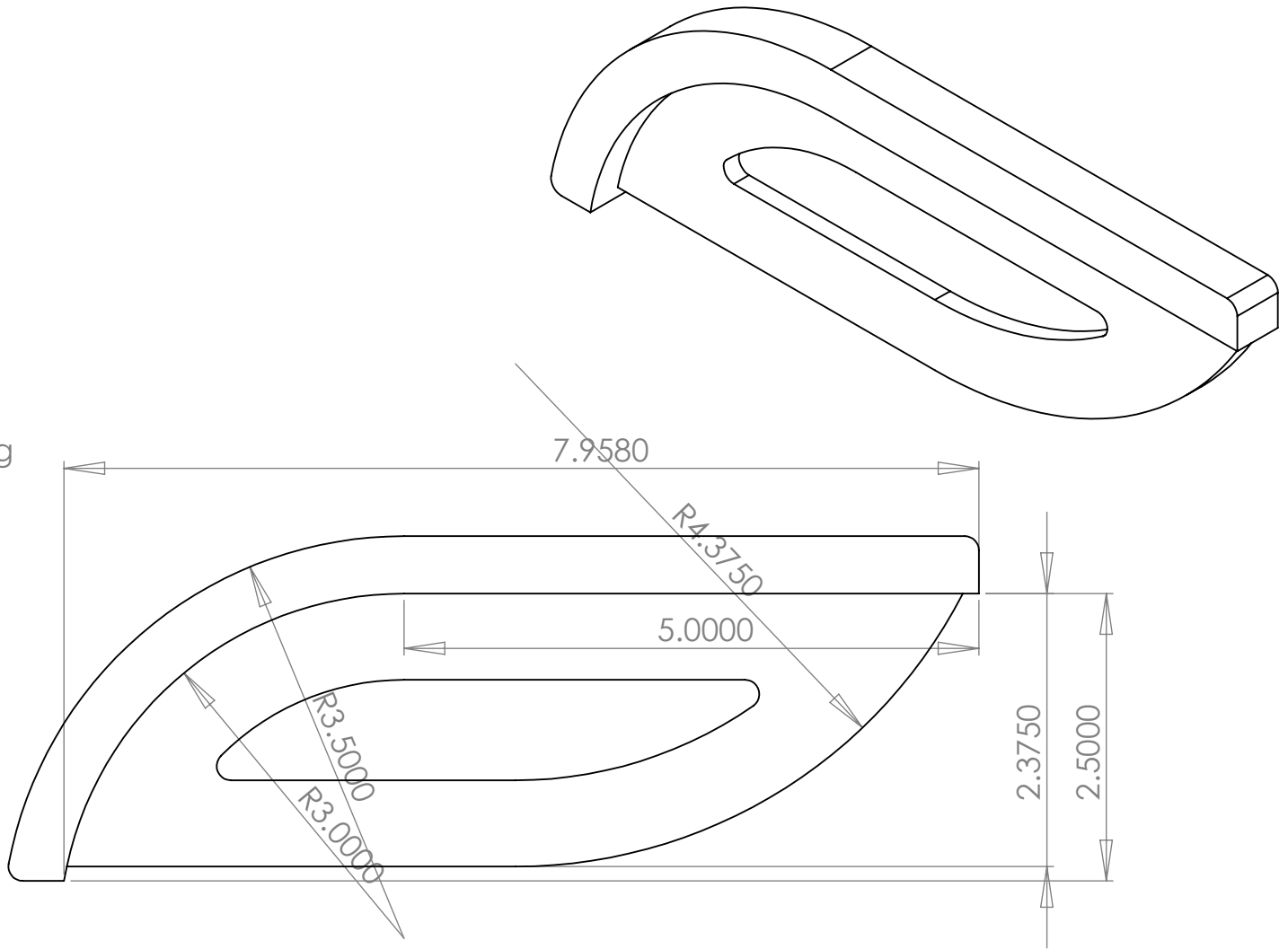

Available in cast Bronze with brown patina or  
White Tombasil (white brass) with matte clear coat

TITLE:

CharlotteR3.0  
for 3" Radius Bullnose

SIZE

DWG. NO.

REV

**A** Charlottecutsh

SCALE: 1:1.5 WEIGHT: 1.74 lbs SHEET 1 OF 1

PROPRIETARY AND CONFIDENTIAL  
THE INFORMATION CONTAINED IN THIS  
DRAWING IS THE SOLE PROPERTY OF  
INTELLICEPT. ANY REPRODUCTION IN  
PART OR AS A WHOLE WITHOUT THE  
WRITTEN PERMISSION OF  
INTELLICEPT IS PROHIBITED.

MATERIAL

FINISH

5

4

3

2

1